

ITEM NO.	PARTNUMBER	QTY.	Description
11	39142-011	1	Tube 0.875 x 0.058
12	39142-012	1	Tube 0.750 x 0.035
13	39142-013	1	Tube 0.375 x 0.035
14	39142-014	1	Tube 1.000 x 0.035
15	39142-015	1	Tube 1.000 x 0.120
16	39142-016	1	Tube 1.000 x 0.035
17	39142-017	9	Tube 0.500 x 0.120
18	39142-018	2	Tube 0.375 x 0.065

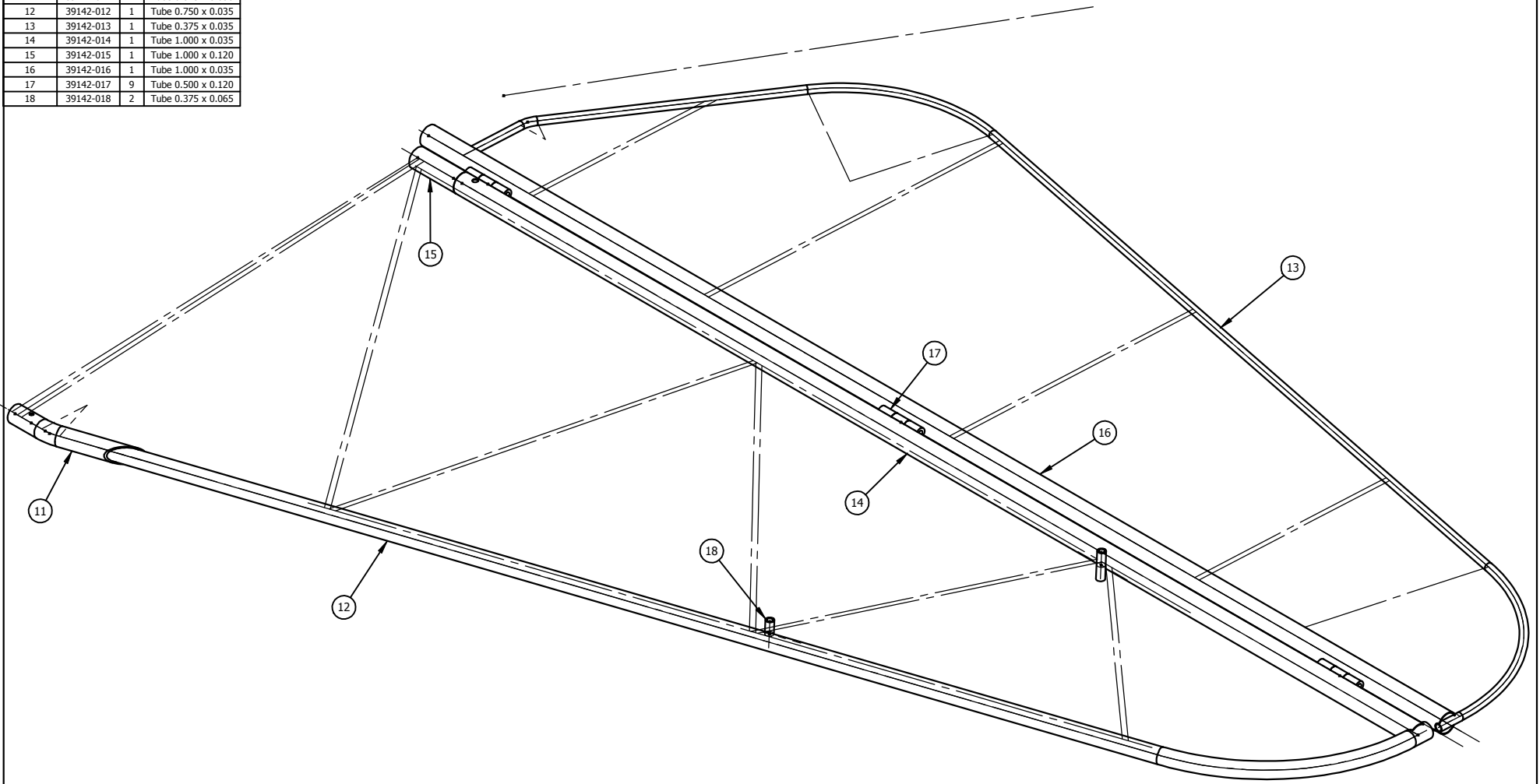

NOTES:

1. QUANTITIES SHOWN ARE FOR LEFT SIDE ONLY. RIGHT SIDE IS IDENTICAL. DOUBLE QUANTITIES AS NECESSARY.
2. THIS IS NOT A DESIGN DRAWING. THIS IS A MANUFACTURING DRAWING INTENDED TO ASSIST WELD ASSEMBLY OF A VR3 PROFILED TUBE KIT.
3. REFERENCE DATA:
TUBE MATERIAL WEIGHT: 14 LBS
NO OF TUBES / SET: 34 PCS
4. ROLLED AND FORMED TUBES REQUIRE END TRIMMING TO SUIT
5. TUBING MATERIALS ARE 4130N AIRCRAFT QUALITY TUBING UNLESS OTHERWISE INDICATED.

REV#	DATE	DRAWN	APPRVD	DESCRIPTION
VR3 ENGINEERING LTD MECHANICAL ENGINEERING & CUSTOM MACHINE DESIGN STRATFORD, ONTARIO, CANADA <small>THIS DRAWING OR THE INFORMATION CONTAINED HEREIN MAY NOT BE REPRODUCED WITHOUT PERMISSION FROM VR3 ENGINEERING</small>				
HORIZONTAL STABILIZER & ELEVATOR WELDMENT: TUBE KIT				
SWICK T				
ISOMETRIC VIEW				
DRAWN: JJ	DATE: APR 28 08	PROJECT NO.	DRAWING NO.	REV NO.
'C' SCALE: 1:5		892-08	39142-01	X